



## KENT KH215/110

The KH215/110 Gully is the side outlet version of our best selling KV215 Gully. They are designed for use primarily in Food/Beverage/Pharmaceutical factories. They are low cost, normally ex stock, and used in both light duty and very heavy duty trafficked areas (depending on the grating chosen). The KH215/110 standard gully takes 10mm thick gratings as well as 3mm thick covers that are made to sit in a 10mm recess (Perforated Gratings, Sealed Gratings). The KH215/110DS version of this gully (DS = Deep Swage) takes all 25mm deep gratings offered by Kent (Mesh, Heelproof Mesh, Factory Ladder, Heelproof Ladder, Gratings). When used with Heelproof Gratings it is suitable also for Civil Projects. In most cases a 110mm or 160mm outlet is required, but this can easily be substituted for a 4" or 6" SCH10 outlet pipe. It is trapped as standard with the Kent Weir Trap.

### Features

- Grade 304 (1.4301) or 316 (1.4401) Stainless Steel to BS EN 10088
- Low Cost
- Strong
- Short lead time
- Usable in both heavy and light duty areas
- Suitable for internal factory drainage and external civil drainage projects

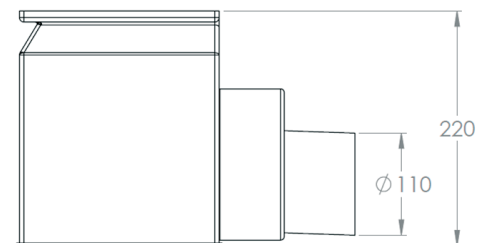
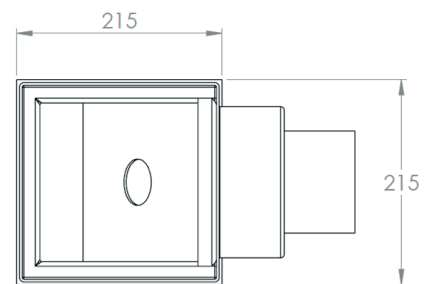
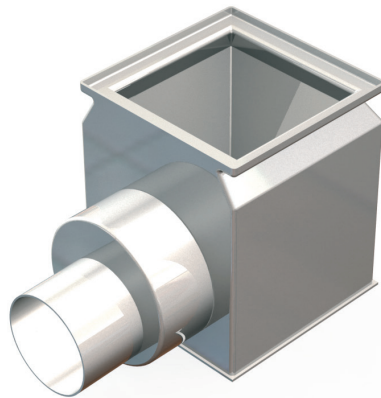

Product Code	Height	Width	Depth	Outlet	Swage	Flow Rate*
KH215/110	220	215	215	110	10	4.42 l/s
KH215/110DS	235	215	215	110	25	4.75 l/s
KH315/110	220	315	315	110	10	4.42 l/s
KH315/110DS	235	315	315	110	25	4.75 l/s
KH315/160	269	315	315	160	10	9.10 l/s
KH315/160DS	284	315	315	160	25	9.85 l/s

\* flow rate is also dependant on grating chosen

**Specify: Kent KH215/110 trapped industrial gully; 215mm x 215mm; grade 304 stainless steel; complete with \_\_\_\_\_ grating.**

Choose the product code from the dimensions table above.  
Add specification options from Page 10-12.

Choose Grating from page 83-92

**BS EN1253 Loading Class L15 / R50 / M125 / N250 / P400**

This gully can be subjected to very heavy loads but must have the correct heavy duty grating to achieve these loads.